

**EXPRESS AIR
BEAST 2000**

**PORTABLE
POLY AIR SCRUBBER**

MODEL #BEAST2000

INSTRUCTION MANUAL

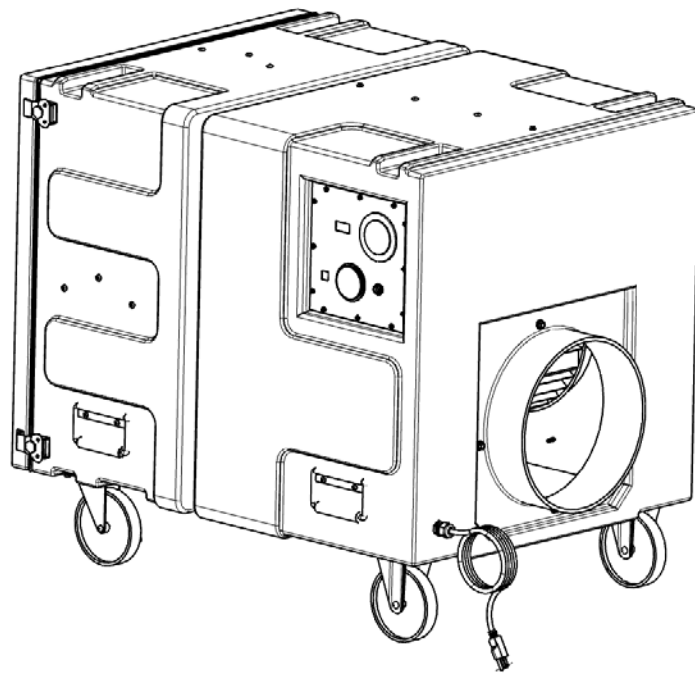

IMPORTANT SAFETY INSTRUCTIONS
READ ALL INSTRUCTIONS BEFORE USING THIS MACHINE.

“READ AND SAVE THESE INSTRUCTIONS”

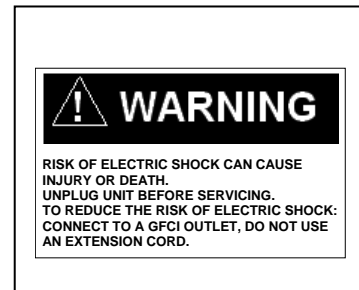

RISK OF FIRE, ELECTRIC SHOCK, OR PERSONAL INJURY

- Unit must be electrically grounded.
- Do not use an adapter.
- Plug into matching three-pronged GFCI receptacle only.
- Do not operate in standing water.
- If electrical components become wet, allow to dry completely before using.
- Unplug unit before performing any maintenance, filter changes or cleaning.
- Inspect cord and plug for damage before use.
- Do not touch cord with wet hands or while standing on wet surface.
- Do not operate in flammable or explosive areas.
- Do not clean unit while plugged in.'
- This unit has been designed for indoor use only.
- Do not use to exhaust hazardous or explosive materials or vapors

IMPORTANT SAFETY INSTRUCTIONS

- a. “Do not operate any unit with a damaged cord or plug. Discard unit or return it to an authorized service facility for examination and/or repair.”
- b. “Do not run cord under carpeting. Do not cover cord with throw rugs, runners, or similar coverings.
- c. Arrange cord away from traffic area and where it will not be tripped over.”



All Nikro Industries Inc. products that have rated efficiencies of 99.97% @ 0.3 microns and/or 99.99% @ 0.3 microns, have H.E.P.A. filters that have been individually tested to meet these minimum efficiencies.

Although all the filters have been pre-tested, the possibility of leaks or filter failure due to handling, transportation, punctures, loaded filters, moisture, wear and tear, etc., does exist.

Therefore, when using this equipment in highly sensitive areas or where any release of particles above and beyond the minimum efficiencies would be detrimental and harmful to humans, plants or property; it is strongly recommended that the units be individually tested prior to their use.

This is to assure that they are maintaining the efficiency levels, which they were designed to filter out.

FAILURE TO DO SO COULD RESULT IN SERIOUS HARM TO HUMAN LIFE, PLANT LIFE AND/OR PROPERTY.



BACKDRAFTING AND CARBON MONOXIDE FUMES

To prevent the backdrafting of deadly carbon monoxide, when using your portable air scrubber to create a negative pressure in a containment area, turn off all open combustion devices such as but not limited to fireplaces, hot water heaters, furnaces, boilers etc.

1115 N. Ellsworth Ave., Villa Park, IL 60181
Telephone: 630-530-0558 FAX: 630-530-0740 Toll Free: 800-875-6457

Your #BEAST2000 Poly Air Scrubbing System has been thoroughly tested and inspected at the factory and is fully assembled and ready for use. However, prior to plugging the unit in, inspect it for any damage that may have incurred during shipping. Inspect and tighten the HEPA filter hold down nuts, which may have loosened during transportation.

ELECTRICAL RATING:

115V 10 Amps 60 HZ

FILTER SET-UP PROCEDURES

The Model #PS2009 Air Cleaning unit is equipped with three stages of filtration as follows:

#550047 1" Polyester Filter Pad (1ST Stage)

#550048 2" Pleated Filter (2nd Stage)

#550046 H.E.P.A. Filter (99.97% efficient @ 0.3 microns) (Final Stage)

The H.E.P.A. Filter is held in place by 4 nuts and 2 – hold down brackets. Slide the brackets over the threaded mounting studs located on the inside of the housing. Thread the nuts over the bracket and tighten securely with a 7/16" wrench. Be sure these nuts & brackets are always tightened securely on the frame of the HEPA filter to guarantee a tight seal with the H.E.P.A. Filter and the filter frame of the unit. The air flow arrows on this filter should always be directed towards the motor and blower assembly. Always turn off and unplug unit when removing or replacing the H.E.P.A. filter. (See Photo 1)

The 2" Pleated Filter should be set in front of the H.E.P.A. Filter. The air flow arrows on this filter should always be directed towards the H.E.P.A. Filter. (See Photo 2)

The 1" Polyester Filter Pad should be placed in the door frame of the unit. Close the hinged door of the unit and snap the latches into the locked position...Unit is ready for use. (See Photo 3 & 4)

An optional Carbon Filter can be used to help control odors. Simply replace the #550048 – 2" Pleated Filter with #860887 – 2" Carbon Filter (sold separately).

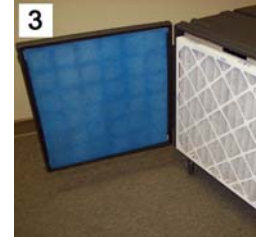
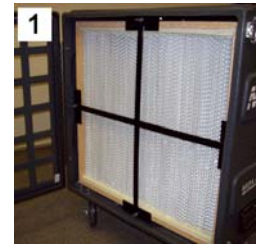

FILTER MAINTENANCE

When performing filter maintenance always wear proper personal protective equipment and clothing. Always follow safe working practices including proper disposal and handling of used filters in accordance with all federal, state and local regulations.

The model #PS2009 Air Cleaning unit is equipped with a Filter-Monitor gauge. This gauge is located on the control panel of the unit. When gauge reads 1.75" or higher, filter maintenance is required and the following steps should be taken:

1. Change the 1" Polyester Filter pad (this filter cannot be cleaned or reused. Dispose of Properly)
2. Close cabinet door and turn unit on.. If gauge continues to read 1.75" or higher go to step #3
3. Change the 2" Pleated Filter (this filter cannot be cleaned or reused. Dispose of Properly)
4. Close cabinet door with all filters in proper position. Turn unit on. If gauge continues to read 1.75" or higher, the H.E.P.A. Filter must be replaced. (This filter cannot be cleaned or reused. Dispose of Properly)

NOTE: FILTERS SHOULD BE REPLACED IMMEDIATELY IF TORN OR DAMAGED.

USE OF ANY OTHER FILTERS THAN ORIGINAL NIKRO REPLACEMENT PARTS VOIDS THE PRODUCT WARRANTY AND PERFORMANCE CLAIMS

TO AVOID CROSS CONTAMINATION CHANGE ALL FILTERS AFTER EVERY REMEDIATION JOB AND CLEAN ENTIRE UNIT THOROUGHLY BEFORE REMOVING IT FROM THE CONTAINMENT AREA.

BEFORE OPERATING THE UNIT

1. Inspect cord and plug for damage.
2. Visually inspect the HEPA Filter for damage, punctures or tears. If you are operating in or exhausting into a highly sensitive area it is strongly recommended that this unit is independently tested to assure proper filtration efficiencies.
3. Inspect and tighten HEPA the filter hold down nuts, which may have loosened during transportation of the unit.

TRANSPORTING AND STORING UNIT

1. Always handle this unit with care. Rough handling such as dropping, or tipping over the unit, bouncing around in a vehicle, and impact from rolling over or off of curbs, stairs and other platforms, could cause serious damage to this unit.
2. Always clean and decontaminate unit before storing it. Store this unit indoors in a dry location.

TROUBLE SHOOTING

PROBLEM	POSSIBLE CAUSE	REMEDY
Machine will not start	Power cord unplugged	Plug cord into outlet
	Blown or tripped circuit breaker	Replace/reset building fuse or breaker
	Tripped thermal protector on motor	Turn off unit and let cool for Approximately 20 minutes, then back on.
Machine will not run continuously	Not enough amperage	Use a larger circuit or remove other appliances from circuit
	Extension cord too long or inappropriate gauge.	Use a 12 gauge extension cord Maximum length 50'

CLEAN AIR EXHAUST DISCHARGE

This portable air scrubber allows the operator to connect a 12" exhaust hose to the unit allowing for remote or controlled exhausting and/or to create a controlled negative pressure in a contained area.

Simply connect a 12" hose (#860243) to the 12" exhaust flange located on the back/exhaust end of unit and extend the hose to the desired area you wish to exhaust to.



#BEAST2000 ASSEMBLY

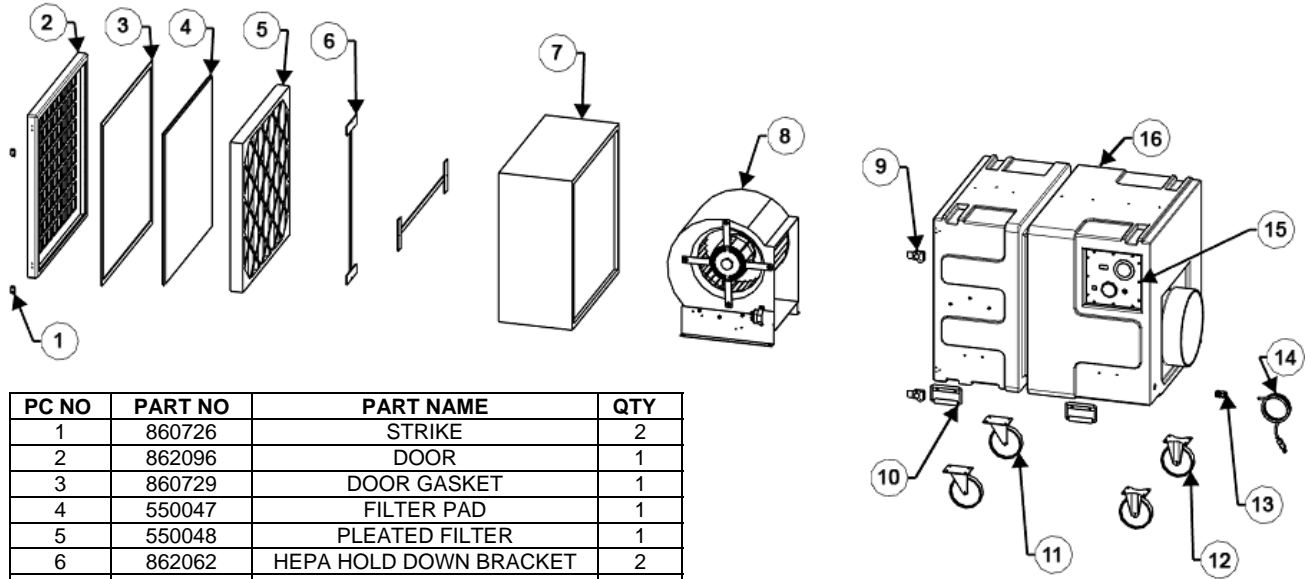

PC NO	PART NO	PART NAME	QTY
1	860726	STRIKE	2
2	862096	DOOR	1
3	860729	DOOR GASKET	1
4	550047	FILTER PAD	1
5	550048	PLEATED FILTER	1
6	862062	HEPA HOLD DOWN BRACKET	2
7	550046	HEPA FILTER	1
8	861297	BLOWER ASSEMBLY	1
9	860725	LATCH	2
10	860724	HANDLE	4
11	862243	FIXED WHEEL	2
12	862244	LOCKING CASTER	2
13	860941	CORD STRAIN RELIEF	1
14	520010	ELECTRICAL CORD	1
15	860402-PS	CONTROL PANEL	1
16	861839	CABINET	1

#861297 BLOWER ASSEMBLY

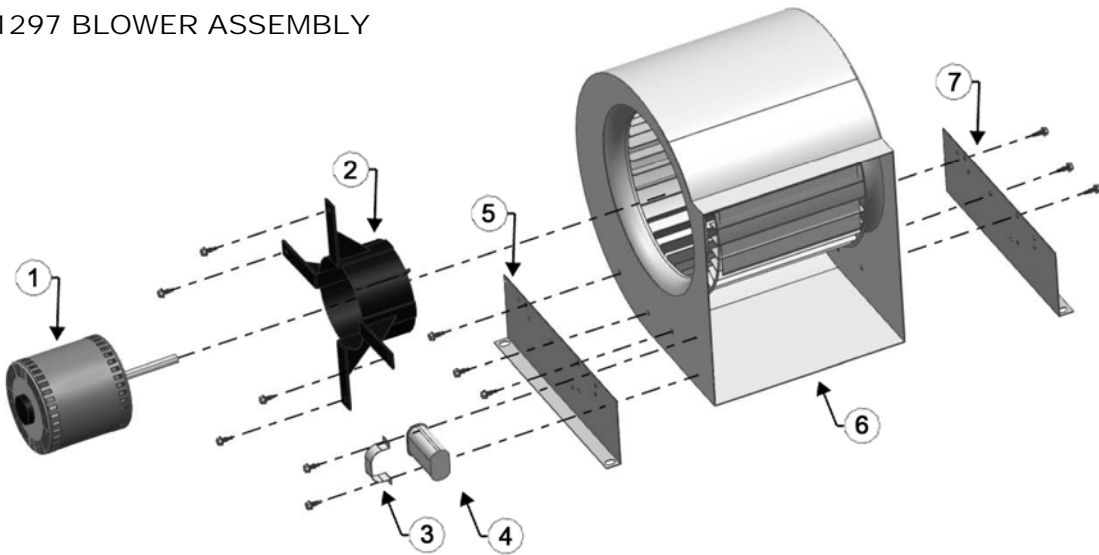

PC NO	PART NO	PART NAME	QTY
1	861295	MOTOR	1
2	862026	MOTOR BRACKET	1
3	861924	CAPACITOR BRACKET	1
4	861392	CAPACITOR	1
5	862131	BLOWER LEG LEFT	1
6	861296	BLOWER	1
7	862130	BLOWER LEG RIGHT	1
	862599	BLOWER ASSEMBLY COMPLETE	

CONTROL PANEL



PC NO	PART NO	PART NAME	QTY
1	861853	THREE WAY SWITCH	1
2	860699	FILTER MONITOR GAUGE	1
3	861854	CIRCUIT BREAKER	1
4	860954	HOUR METER	1
5	860721	GAUGE RELIEF BARB	1

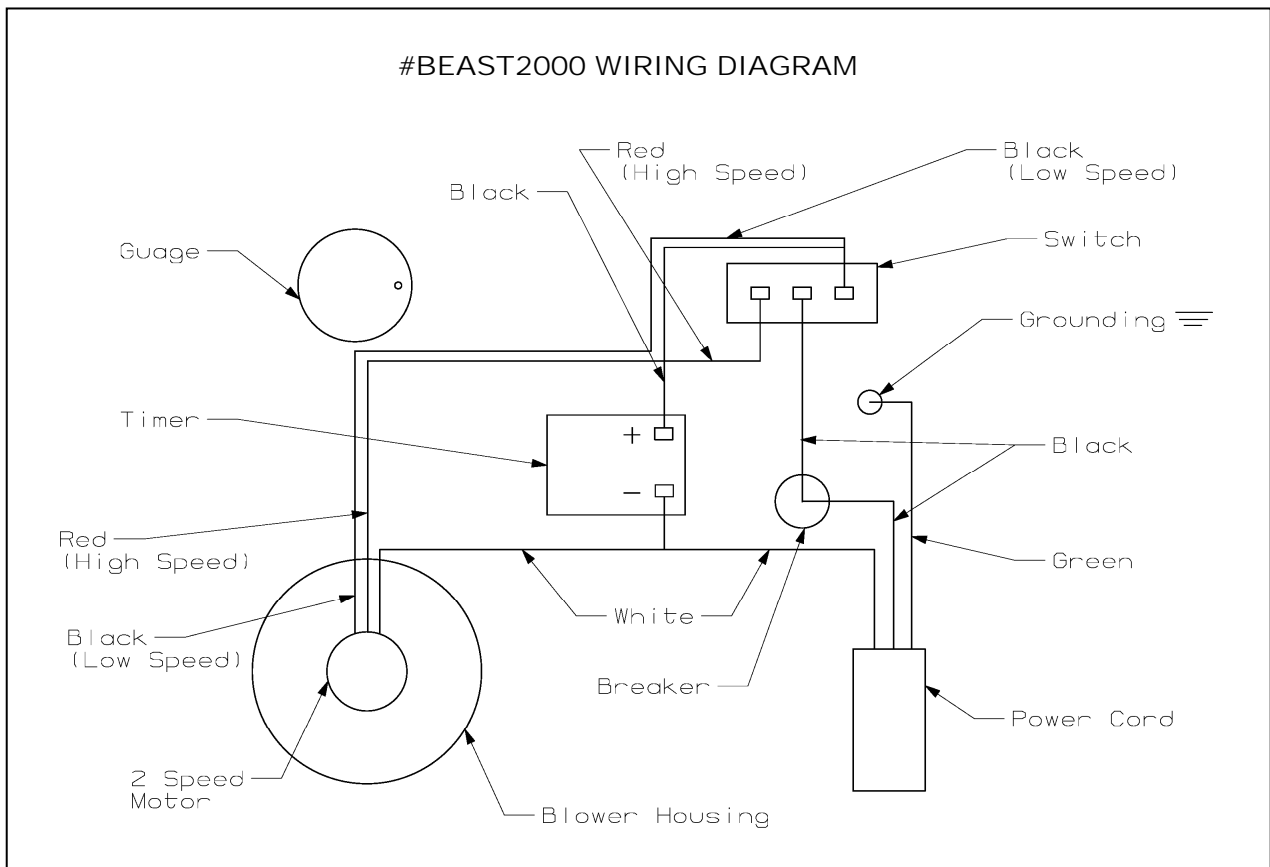

WARRANTY

Nikro Air Scrubbers are warranted for 1 year from the date delivered to the original end user and may not be assigned or transferred.

Parts, which become defective due to faulty workmanship or materials during normal use in this period will be repaired or exchanged at no charge if returned and approved by an authorized Nikro service center. All replaced or repaired parts shall only be warranted for the remainder of the original one year warranty period.

After the expiration of the one year warranty, all warranties on this unit including fitness for a proposed usage or purpose will become void.

The end user shall be responsible for freight charges incurred to deliver warranted product to an approved Nikro service center. Nikro shall be responsible for freight charges incurred in returning unit to customer, but not to exceed the original freight charges to customer.

It shall be wholly Nikro's decision to repair, replace or refund the purchase price of any such defective goods.

This warranty does not apply to normal wear and tear, neglect, misuse, abuse or incorrect installation. If any other replacement parts, filters or attachments are used other than original Nikro parts, this warranty will become void.

Nikro disclaims responsibility for loss of production, profits, goodwill or any other costs that may indirectly occur due to the failure of this product.

H.E.P.A. FILTER STANDARDS AND CERTIFICATION

All Nikro H.E.P.A. filters are manufactured and individually tested using the MIL-STD 282 D.O.P. test, or the IEST-RP-CC-001.3 test method.

Each filter is tested and certified to have a minimum efficiency of 99.97% @ 0.3 micron particles. All filters are then individually labeled and registered by the manufacturer.

All H.E.P.A. filters used in Nikro equipment meet, and in most cases, exceed the minimum standard of 99.97% efficiency @ 0.3 micron particles, and comply with OSHA and EPA standards for cleaning the air of toxic and nuisance dust such as mold, lead and asbestos.

ELECTRICAL CERTIFICATION



ETL LISTED
CONFORMS TO UL STD 507
CERTIFIED TO CAN/CSA STD C22.2 NO. 113